

Objectives

1. To introduce and illustrate the idea of design patterns
2. To introduce some key design patterns students have used or will use:
 - Decorator (Wrapper/Filter)
 - Abstraction-Occurrence
 - Observer
 - Iterator
 - Factory
 - Proxy
 - Singleton

Materials

1. “Gang of Four” Design Patterns book to show
2. Projectable of pp. 6-7 of “Gang of Four” book (general description of “pattern language”)
3. Projectable of p. 127-128 (the Singleton pattern)
4. Projectable of figures 6.1 and 6.2 from Lethbridge/Langaniere
5. Demo and handout of Iterator demo
6. Projectable of abstract sequence diagram for Observer pattern (p. 295)
7. Projectable of simple Observer demo (tic-tac-toe)
8. Demo and handout of Observable demo
9. Demo and handout of swing program with buttons with different looks and feels
10. Projectable of “Gang of Four” book page 175

I. Introduction

A. One of the characteristics of an expert in many fields is that the expert has learned to recognize certain *patterns* that characterize a particular problem or call for a particular approach to a solution.

Examples:

1. A civil engineer uses certain structural patterns when designing bridges, highways, etc.
2. A Medical Doctor recognizes certain patterns of symptoms as indicative of certain diseases.

B. In the world of OO software in recent years, there has been a growing recognition of the value of studying *design patterns* - standard patterns of relationships between objects in a system (or portion of a system) that constitute good solutions to recurring problems.

1. Much of this was inspired by a lecture by Christopher Alexander - an architect - given at OOPSLA 1996. Alexander is an architect - and spoke about patterns in relationship to that field - but software engineers have recognized that the same principles apply in other fields like ours.

In one of his books, he gave the following definition of a pattern:
“Each pattern describes a problem which occurs over and over again in our environment, and then describes the core of the solution to that problem, in such a way that you can use the same solution a million times over, without doing it the same way twice.”

2. A key book in this regard is the book *Design Patterns* by Gamma, Helm, Johnson, and Vlissides (known in OO circles as “the Gang of Four”).

- a) SHOW

- b) This book classifies the patterns it discusses into three broad categories, which were also discussed as homework exercise m. What are they?

ASK

3. One important characteristic of the study of patterns is the idea of giving each pattern a name, so that when people talk they can use the name of the pattern and others will know what they are talking. (Unfortunately, some key patterns have more than one name; but at least we don't have the issue of the same name referring to different patterns!)
4. In addition to giving the overall pattern a name, we also give a name to the various objects that participate in the pattern. Here, the name given to each object is meant to describe its *role* and *responsibilities*. The object does not have to actually be called by this name - the purpose of the name in the pattern is simply to help us understand how responsibilities are apportioned.

EXAMPLE: At the present time, the person who has the role and responsibilities of President of the United States is George W. Bush. We may refer to him as “the president” - but his parents did not name him president, they named him George!

- C. In this lecture, we will try to illustrate the concept of design patterns by introducing several examples of design patterns - each of which is a good way to solve a particular kind of problem in a software system.

1. Obviously, one only wants to use the pattern if it meets a real need, of course!
 2. Most are patterns you have already used - some in CS112; some in labs or your project.
- D. We will begin with an example you've already used, and show how to describe it using "pattern language".

In standard discussions of patterns (including the "Gang of Four" book), it is common to describe patterns in a standard way.

PROJECT: pp. 6-7 of "Gang of Four" book

(Note: we will discuss patterns from other sources as well - but the "style" of this book is an accepted standard regardless of where the pattern descriptions come from.)

II. The Singleton Pattern

- A. We will begin by talking about a pattern that you are already quite familiar with. One of our goals will be to use it as an example of how patterns are described. The singleton pattern is applicable wherever there is a kind of object where it is necessary that there be one and only one copy of this object in existence.
- B. It belongs, therefore, to the category of creational patterns.
- C. Project, go over pages 127-128 of the "Gang of Four" book

III. The Abstraction-Occurrence Pattern

- A. One pattern you have been using in your video store project is a pattern called the Abstraction-Occurrence pattern. Can anyone describe this pattern and how it relates to the video store project?

ASK

- B. In terms of the three categories of pattern we discussed earlier, to which category would this pattern belong?

ASK

Structural

C. This pattern actually doesn't appear in the "Gang of Four" book. The author of one book that does discuss it introduces this pattern this way: "Often in a domain model you will find a set of related objects that we will call *occurrences*; the members of such a set share common information but also differ from each other in important ways.

Examples: *ASK*

D. This particular situation is one to which it turns out there are both good and bad solutions. The idea is to represent the various occurrences in some way that avoids duplicating the common information.

1. In general, the clean solution is to use two classes - an « abstraction » class and an « occurrence » class.

PROJECT: Figure 6.1 of Lethbridge/Langaniere

2. The author of this book also notes that there are a number of possible "antipatterns" (or poor solutions.) Let's look at several and discuss why each is not a good way to solve the problem.

PROJECT: Figure 6.2. of Lethbridge/Langaniere

Discuss why each "solution" is not good

- a) This example is undesirable because of replication of information. It would become even worse if some of the common information were subject to change, since it would have to be updated multiple times.
- b) This example is undesirable because each new instance of the abstraction (e.g. new book title) would require creation of a new class - necessitating recompilation of the software and resulting in a proliferation of classes.
- c) This example is undesirable because it involves replication of information again - even though the occurrence class does not have attributes for the information, its base class (and therefore every one of its objects) does.

E. This particular problem illustrates one of the virtues of studying design patterns - you can find a clean solution to a problem, while avoiding mistakes that would otherwise be easy to fall into.

IV. The Iterator Pattern

A. Another pattern you have used is the Iterator pattern. The Iterator pattern prescribes three roles: a collection, an iterator over the collection, and an object that uses the iterator to systematically visit all the items in the collection.

B. What category of patterns would this belong to?

ASK

Behavioural

C. To see the motivation for the pattern, suppose that we had a collection of Strings, and we want to perform various operations on all the strings in the collection at various points in the program. Suppose, further, that the collection of Strings were stored in an array.

```
String [] someCollection;
```

1. Now, we could systematically print all the strings by using a loop with an index into the array:

```
for (int i = 0; i < someCollection.length; i ++)  
    System.out.println(someCollection[i]);
```

2. Suppose, at some other point in the program, that we want to print out the shortest string in the collection (and suppose that they are not necessarily stored in order of length.) The following code would work (assuming the collection contains at least one string.)

```
String shortest = someCollection[0];  
for (int i = 1; i < someCollection.length; i ++)  
    if (someCollection[i].length() < shortest.length())  
        shortest = someCollection[i];
```

3. In similar fashion, we could write code to find the alphabetically-first (or last) string, or to print out all the strings that begin with the letter 'A', or whatever.

4. Now suppose we decide to use a different collection to store the strings - perhaps a Set or a List or whatever. All of the code would need to be modified to change the way it accesses the strings; further, the code would need to know the details of how the collection is stored.

D. A better approach is to separate the notion of “iterating over all the elements in the collection” from the details of how the collection is stored. This decoupling is accomplished by an *iterator*.

1. An iterator is always attached to some collection. Usually, a collection has some method that creates an iterator for the collection - so the way that an iterator is constructed is by asking the collection to create one. At any time, a given collection may have any number of iterators in existence.

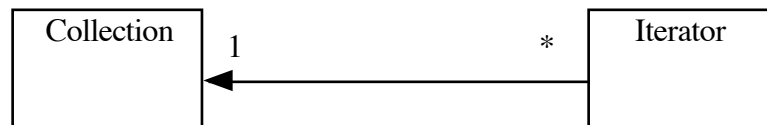

2. Moreover, an iterator always either refers (implicitly) to some element in the collection, or is at the end of the collection. If a collection has several iterators, each has its own position relative to the collection.
3. An iterator has three basic responsibilities:
 - a) Report whether or not it currently refers to an element of the collection.
 - b) If it does refer to an element of the collection, provide access to that element
 - c) Advance to the next element of the collection
4. An iterator provides access to the elements of the collection in some order that is defined by the underlying collection - but which always satisfies certain properties.
 - a) A newly-constructed iterator always refers to the “first” element of the collection. (Where “first” is defined by the underlying collection - e.g. if the collection is a Set, the choice may appear arbitrary but actually obeys some consistent rule that the user of the iterator need not be aware of.)
 - b) If the iterator is used to systematically visit each element of the collection (by repeatedly accessing the current element and advancing to the next), every element of the collection will be visited exactly once in some collection-specified order, and then the iterator will become past the end of the collection.

5. If code is written to access all the elements of a collection through an iterator, and the kind of collection is changed, the only other code that may (or may not) need to be changed is the code that asks the collection to create the iterator.
- E. The `java.util` package defines an `Iterator` interface, and each of the collections it supports have an `iterator()` method that creates a new iterator and returns it.
1. The Java iterators differ slightly from the responsibilities I have presented above:
 - a) The operations of accessing the current element and moving on to the next element are combined in a single method.
 - b) An iterator can also support a method for removing the last element visited from the collection.
 - c) Thus, the Java `Iterator` interface contains three methods
 - (1) `hasNext()` - true unless past the end of the collection
 - (2) `next()` - combines accessing the current element with moving on to the next
 - (3) `remove()` - remove from the collection the last element that was returned by `next()`. An iterator for a particular type of collection is not required to actually support this operation.
 2. As you discovered in lab, you cannot create an iterator for a `Map` directly. That's because a `Map` actually involves *two* collections - a collection of keys, and a collection of values - plus an association between members of the two collections. Thus, to iterate over a `Map`, you must use the `Map`'s `keySet()` or `values()` method to get access to the appropriate set, and then get an iterator from it.
- F. We have seen the `Iterator` pattern used in another place. Where?

ASK

The `JDBC ResultSet` - a `ResultSet` has a method called `next()` which performs functionality similar to that of both the `hasNext()` and `next()` methods of an `Iterator`, but in a different way. (It's a bit confusing that `JDBC` didn't follow the pattern more closely, IMHO)

G. An example of implementing the Iterator pattern

1. Handout Discuss Iterator demo code
2. Run it
3. Go over it
4. **AN IMPORTANT NOTE:** Unless one is building a collections package, one normally doesn't have to actually implement iterators - just use them. The implementation is include here so you can see how iterators actually work.

H. Next semester, you will be learning how collections are actually implemented, and will use C++. The C++ standard library also defines iterators, which work the same way, though the names of the methods are different:

1. A collection will have a method called `begin()` to create an iterator that refers to the start of the collection.
2. A collection will have a method called `end()` to create an iterator that is one past the end of the collection. Two iterators to the same collection can be compared to see if they refer to the same point by using `==`.
3. The element an iterator refers to is accessed by using the `*` operator.
4. An iterator is advanced to the next element by using the `++` operator.

Thus, C++ code for printing all the strings in a collection of strings similar to the example we have done in Java would look like this:

```
for (someCollection::iterator iter =
    someCollection.begin();
    iter != someCollection.end(); iter ++)
    -- code to write out * iter;
```

(I've shown you this C++ code now, because you'll see a lot of code like this next semester, and it will be helpful to recognize then what pattern is being used.)

5. Actually, C++ iterators can be bidirectional - i.e. allowing one to either move forward or backward within the collection. Some collections support a reverse iterator that allows you to get an iterator that refers to the last item in the collection and then work backwards from there.

V. The Observer Pattern

- A. The Observer pattern is useful when we have two kinds of objects called an observable (or subject) and an observer, that are connected in such a way that the observer needs to know about changes in the observable, but we want to minimize the coupling between these objects.

(The view and model classes in an MVC system are a good example of this - when the model changes, the view(s) may need to change - but we don't want to tightly couple the model and view. Thus far, we have not used the Observer pattern to implement an MVC system, largely because our example systems have been very simple.)

- B. In the Observer pattern, we have two kinds of classes: an observable class, and one or more observer classes, with specific responsibilities.

1. The observable maintains some information that is of interest to the observer(s), and is responsible furnish that information to it/them upon request.
2. Each observer is responsible to *register* itself with the observable, by calling some registration method.
3. When the observable changes, it is responsible to notify each of its registered observers about the change. The notification may include some indication as to what has changed (though the pattern does not mandate this.)
4. Each observer is responsible to have an appropriate method which the observer can invoke when it changes.
5. Each observer, in turn, is responsible to look at the notification it received and - if something of interest to it changed - request appropriate updated information from the observable.

PROJECT - Abstract sequence diagram for this pattern from "Gang of Four" book p. 295

- C. The Java standard library provides support for this pattern

1. The API defines a class called `java.util.Observable` and an interface called `java.util.Observer`.
 - a) `Observable` is a class because it implements behaviors that any observable object needs; but if an observable inherits them, then it does not need to implement them itself.
 - b) `Observer` is an interface because all that is required to be an observer is that one have a method called `update()` that allows the

observable to inform it of changes. What this method actually does varies greatly from situation to situation, so there is no benefit to inheriting any implementation.

2. An observer registers itself as being interested in being notified of changes to an observable by calling the method `addObserver()` of the observable.
 3. Any code that changes an observable calls a method of the observable called `setChanged()` and then calls `notifyObservers()` to actually report changes to its observers. (Usually, these calls are part of the code of a method of the observable object.)
 - a) `notifyObservers()` can be called without the object having changed, in which case nothing happens. Once `notifyObservers()` has been called the observable is considered unchanged until `setChanged()` is called.
 - b) Several changes can be made before observers are notified to reduce overhead, if desired.
 4. When an observable has changed and `notifyObservers()` is called, the `update()` method of each registered observer is called.
 - a) The first parameter to `update()` is the observable that has changed.
 - b) The second parameter is an optional parameter to `notifyObservers()` that can specify the *nature* of the change. It is often null.
 5. When an observer's `update()` method is called, it is responsible to use an appropriate method or methods to access the observable to get at the new information, and then to take appropriate action.
- D. A simple example: A program that plays tic-tac-toe might have a model class called `Board` and a view class called `BoardDisplay`

PROJECT Sample code and go over use of pattern

E. Another example: Observer Demo

1. The program consists of an observable object that records a temperature, and three views that report the temperature using three different scales (Celsius, Fahrenheit, and Kelvin.) A new temperature can be typed in any view, and all three views are updated to reflect the new temperature.
2. *DEMO*
3. *HANDOUT* - source code - go over

VI. The Proxy Pattern

- A. The next pattern is one we used in our distributed systems example.
- B. Recall the structure of the student registration system; and the approach we used to create a distributed version with rmi:

Original version:

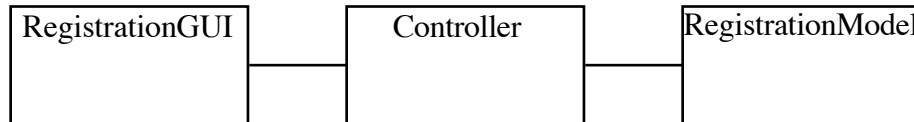

Distributed version:

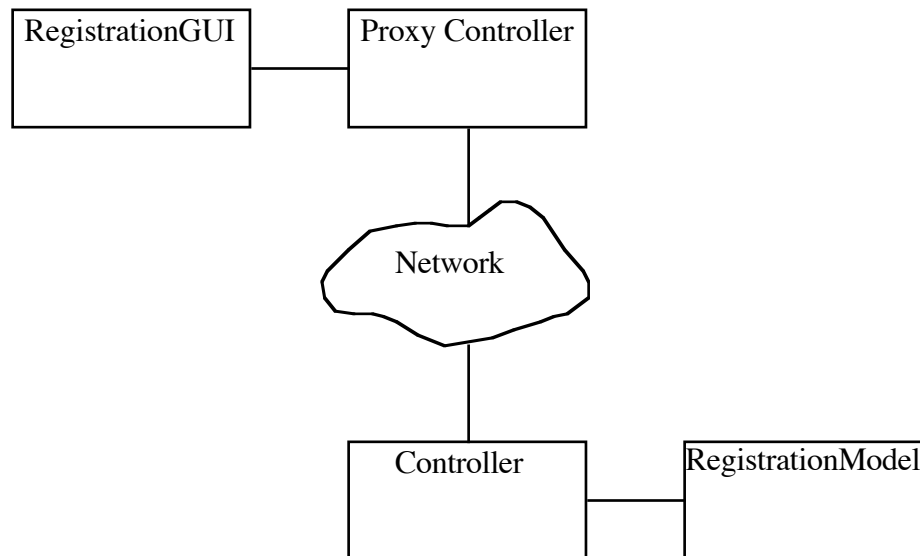

1. The proxy controller running on the remote computers has the same interface (the same set of methods) as the “real” controller running on the main computer.
2. The GUI code communicates with the proxy controller in just the same way it would communicate with the only controller if the system were not distributed. (I.e. it calls the same methods with the same parameters.)
3. What the proxy controller does, whenever a method is called, is to convert the name of the method and its parameters into a suitable message which is sent over the network to the real controller. When the real controller has processed the request, it sends the results back

over the network to the proxy controller, which in turn sends the appropriate information back to the GUI.

4. From the standpoint of the GUI, it looks like all operations are being performed locally - though in fact, the two controllers are communicating over the network. (The only noticeable difference might be time lag.)

VII. The Factory Pattern

- A. The factory pattern is a fairly sophisticated pattern that is a bit hard to get a hold of. Perhaps the best way to get a handle on it is to show an example of a place where it is used. The illustration we will use is not one where the factory pattern is visible on the surface, but it plays a key role behind the scenes.
- B. As you recall, earlier in the course we discussed the Java swing package, which incorporates the notion of “pluggable look and feel”. In essence, what this means is that, when a GUI component (e.g. a button) is created, it displays itself using in the way appropriate to its look and feel. It turns out that how a component displays itself is determined when it is created.
 1. Example - it is possible to create a swing program with several buttons that have different looks and feels. (Not a good idea in general, but we do this here for illustration.)
 2. Demo program.
 3. Handout / discuss code
- C. Behind the scenes, this functionality is implemented by using *factories*.
 1. A factory is an object that creates other objects. It is possible to have different factories that have the same interface - i.e. produce objects of the same general kind - but each produce their own kind of object.
 2. In essence, Swing uses factories to produce the various components that can displayed, which are different for different looks and feels. Each factory has methods for producing each of the various kinds of components. (The explanation given here is vastly simplified.)
 3. The `setLookAndFeel()` method chooses a particular factory, and when components are subsequently created, their visible representation is “manufactured” by the current factory

VIII. The Decorator Pattern (also known as Wrapper, Filter)

A. PROJECT “Gang of Four Book” page 175.

B. Where have you met this pattern before?

ASK

C. The java.io package makes extensive use of the Decorator pattern. Basically, this pattern provides a way to enhance the functionality of an object without changing the code for its class.

1. Example: the java.io package provides many kinds of InputStreams - objects that can read streams of bytes from a variety of different sources - e.g.

a) FileInputStream - reads bytes from a disk file

b) ByteArrayInputStream - “reads” bytes from an array

c) PipedInputStream - reads bytes from a pipe (a connection between two processes running on the same computer such that one process can “feed” data to another through the pipe).

d) A network socket - reads bytes sent over a network from another computer.

2. Recall that, in java, characters of text are not represented by single bytes, but by using Unicode, which represents characters as pairs of bytes.

a) Therefore, the java.io package defines a Reader class (and various subclasses) that supports a read() method that reads a single character from some source.

b) Many platforms represent characters in their files etc. using an encoding like ASCII, where a character is represented as a single byte - but other platforms may use some other encoding (Some encodings use one byte for common characters, and two bytes (or even three) for less common ones.) Thus, when a Reader needs to read a character from some source, it may actually need to read just one byte and pad it out with 0's - or it may need to read two or even three bytes.

- c) The java.io package also includes a wrapper called `InputStreamReader` that allows any input stream to function as a Reader - i.e. each call to its `read()` method reads the appropriate number of bytes from the underlying input stream and returns the result as a Unicode character.
3. Moreover, when processing text programs often need to work with complete lines of text - not just individual characters. A line of text is a sequence of characters terminated by a line terminator.
- a) However, the line terminator is platform-specific and environment-specific
 - (1) On Unix systems (include Macintosh OSX), it is the single character newline (`'\n'` - ASCII code 10)
 - (2) On Macintosh Classic systems, it is the single character return (`'\r'` - ASCII code 13).
 - (3) On Windows systems, it is a sequence of two characters return, linefeed.
 - b) Therefore, the java.io package includes a wrapper called `BufferedReader` that allows any reader to be used as a source of complete lines. A `BufferedReader` has - in addition to the standard individual character `read()` method - a `readLine()` method that keeps reading characters until it has read a line terminator, and then returns a String composed of all the characters read except the terminator (i.e. a platform-independent representation of the contents of the line.)
4. You may recall a lab last year in which you dealt with encrypting and decrypting messages. In particular, one copy of the program - running on a particular computer - could encrypt a message and send it over the network to another copy of the program running on a different computer, which would then decrypt and display it. Each message was a single line - which could, of course, consist of an arbitrary number of characters.
- a) The following code appeared in code that was executed on the “receiver” side to handle an incoming message, and served to create an object that could read the message:

```

BufferedReader input = new BufferedReader(
    new InputStreamReader(
        connectionSocket.getInputStream()
    )
);

```

This created an object that looks like this:

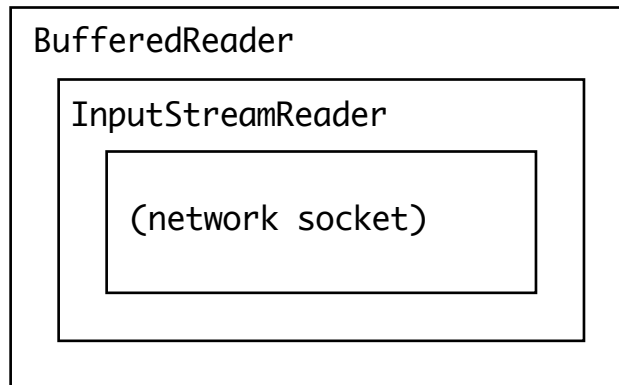

- b) The following code was then used to actually read the message that was sent over the network from some other computer:

```
String message = input.readLine();
```

When this code was executed, the input object asked its “inner reader” to read characters repeatedly until a line terminator was seen. The “inner reader” in turn repeatedly asked the network socket for individual bytes and converted them into characters.

5. A major advantage of the “wrapper” approach used by the java.io package is that it avoids a proliferation of classes. - e.g. we don’t need a special kind of BufferedReader for files, and a different one for pipes, and a different one for network connections, etc. - instead, a single BufferedReader wrapper can build the necessary functionality on top of any kind of Reader; and a single InputStreamReader wrapper can build the necessary functionality on top of any input stream.
- D. In general, this decorator (wrapper) approach is useful whenever we have a class whose functionality we want to extend, but we have good reason not to modify the source code for the class itself. We put the added functionality into a wrapper, that also forwards original requests to the object within.